

Pellet boiler



ecotop^{zero} and ecotop^{light}



Pellet gasification technology

- + Remote control via mySOLARFOCUS app
- + Weather forecast function
- + Optional fine dust separator

SOLARFOCUS

Clean air thanks to
Zero Emission Technology





Heating comfort

is living comfort

There are two models available from the **ecotop** series:

ecotop^{zero} has a dust filter integrated as standard. It's dust emissions are almost zero.

ecotop^{light} is without integrated dust filter. And even without a filter, the boiler reaches 5 stars in the Italian subsidy system. The boiler can integrate the dust filter at any time later.

Thanks to its compact design, the **ecotop**^{zero} / **ecotop**^{light} is a real space saver. It can be set up close to the wall on two sides.

Due to the plug-in delivery of the **ecotop**^{zero} / **ecotop**^{light}, (fully wired, assembled, checked and pre-set) additional costs are saved.

As **ecotop**^{zero} / **ecotop**^{light} is delivered ready for use (fully wired, assembled, tested and preset) additional assembly costs are avoided.

Sectional view

(1) Intermediate container for pellets with suction turbine (2)

The **ecotop^{zero}** has a generous intermediate pellet container. The suction turbine ensures filling in a closed circuit (suction-pressure system) at specified times. The heating room and pellet storage room must not be directly next to each other. The suction turbine is mounted directly on the intermediate pellet container with sound insulation. This system is maintenance-free and a closed circuit.

(3) Single axis rotary valve

100% backburn-proof even if there is a power failure. Minimum power consumption. No chains or gear wheels - low noise and maintenance free.

(4) Stainless steel grate

(5) Automatic ignition

(6) Air volume measurement

The differential pressure sensor that measures and regulates the air volume necessary for a perfect combustion.

(7) Downfiring combustion technology

Using this technology temperatures up to 1,200 °C are reached in the combustion chamber.

(8) Heat exchanger cleaning system

(9) Fine dust separator

In order to filter the last, not yet separated dust particles out of the exhaust gas, the **ecotop^{zero}** is equipped with a fine dust separator. The cleaning of the spray and separation electrodes is fully automatic and done together with the heat exchanger cleaning. External cleaning facilities, often associated with additional costs, are therefore not necessary.

(10) Induced draft fan

(11) Automatic ash extraction

The ash is automatically transported into a 20 litres ash box. The long runtime intervals increase your heating comfort. On request, your cell phone will notify you when the ash box is to be emptied.

Integrated return booster module

The integrated return booster module with mixer motor to charge the buffer tank is a space saver and is a timesaver in installation of the boiler.

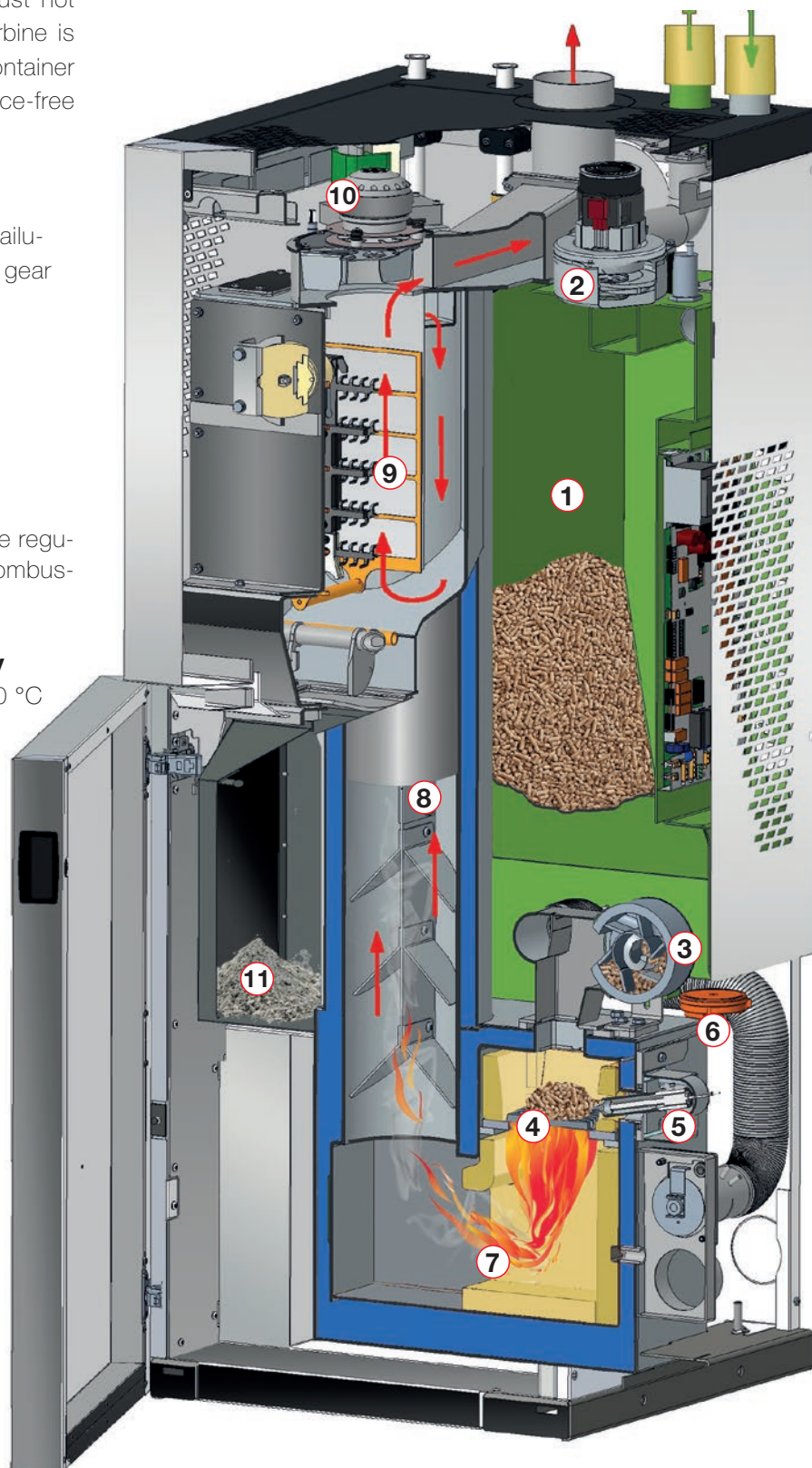

Versatile thermoregulation

The intuitive thermoregulation **eco** manager-touch enables individual settings and ensures a perfectly tailored heating management. The temperature regulation is simple thanks to the 7" touch display. Not only the boiler is regulated but the entire heating system also. In this way all SOLARFOCUS products in the energy network communicate with each other and optimize the system.

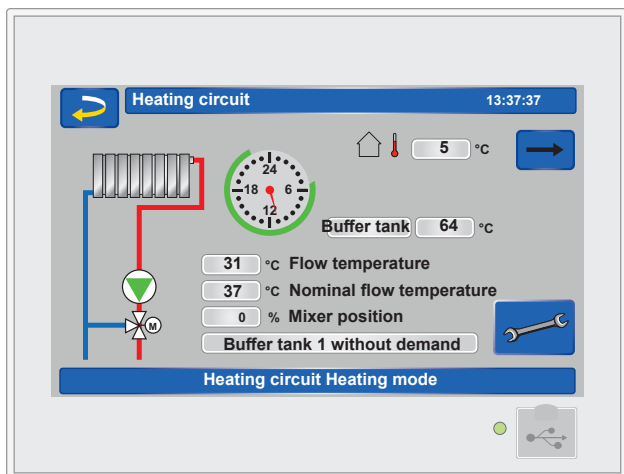

Weather forecasting function

The weather forecasting function (Weatherman function) is integrated into all SOLARFOCUS boilers as standard. This remarkable innovation not only gives the user added convenience but also helps saving money. The control unit accesses live data from a weather server and uses this to tell the **ecotop** zero when to heat – or when to remain inactive, because sunshine is expected.

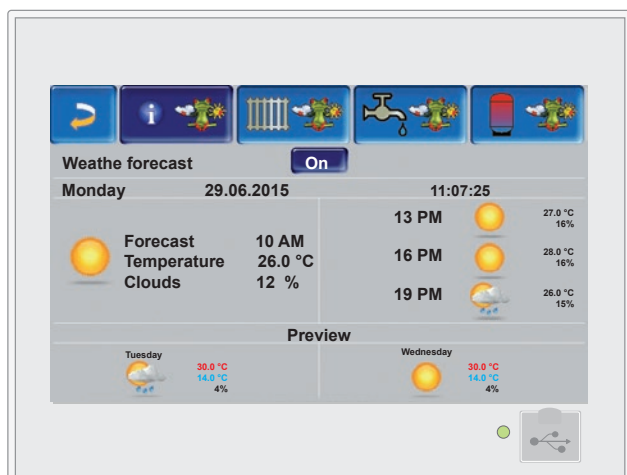

my **SOLARFOCUS**-App

You can control the heating system even more comfortably with the my**SOLARFOCUS** app. In combination with the Weatherman function, it takes just a few seconds to set your heating via your smartphone. It does not matter where you are, in the office, on the couch or on vacation.

App for smartphone (Android and Apple) with attractive design for intuitive operation of the main heating parameters. It gives the possibility to visualise even the solar yield with the installed heat meters and central control unit via **eco** manager-touch.

Everything at a glance:

status of the heating circuit pumps, various boiler values, buffer and DHW tank, flow temperature and much more. Via the modbus TCP connection, SOLARFOCUS products can be integrated into SMART HOME solutions without additional extensions.

- + Intuitive control unit with 7" touchscreen display
- + Takes the weather forecast into consideration
- + my**SOLARFOCUS**-App



Storage and feeding systems

Suction head module with suction heads

- + Max. hose length 20 m (Boiler - Suction head module)
Max. transport height 2,5 m (Boiler - Suction head module)
- + Optimum utilisation of space
Minimum installation effort

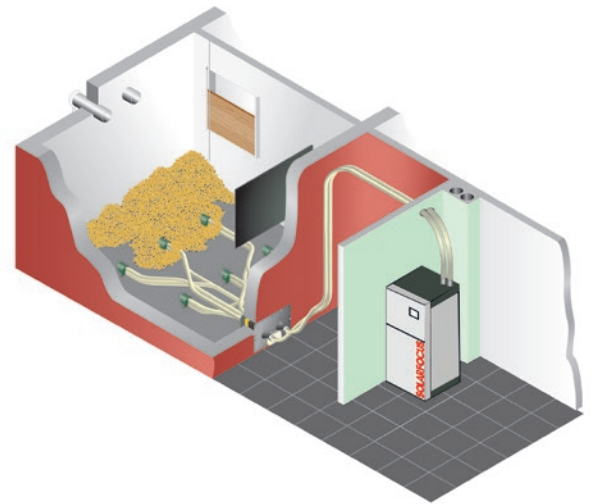

Suction head module with suction auger

- + Maximum hose length 35 m
Maximum transport height 5 m
Maximum auger length 6 m
- + Complete storage room emptying

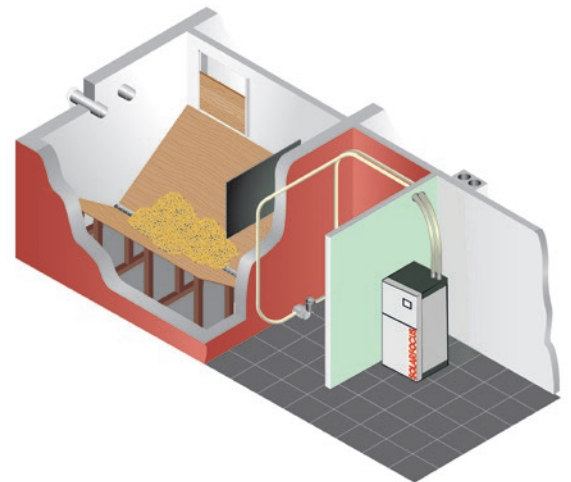

Pelletbox with suction system

With suction auger

- + Max. hose length 35 m
Max. transport height 5 m
- + Container volume up to 9200 kg

With suction head

- + Max. hose length 20 m
Max. transport height 2,5 m

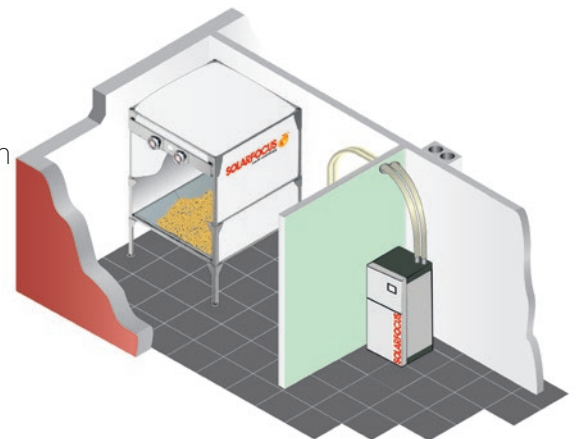

350 litre pelletbox with suction head, for manual filling

- + Maximum hose length 20 m
Maximum transport height 2,5 m

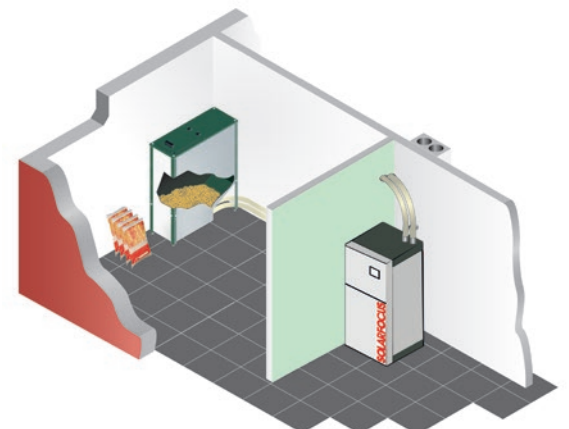

Hydraulic integration

The return booster module with mixing motor and pump are already mounted.

ecotop with stratified storage tank and fresh water station FWM

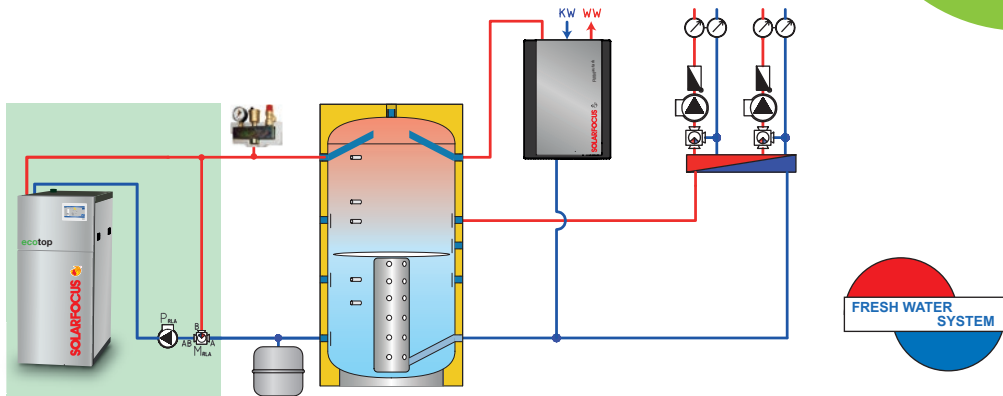

ecotop with HYKO and solar system

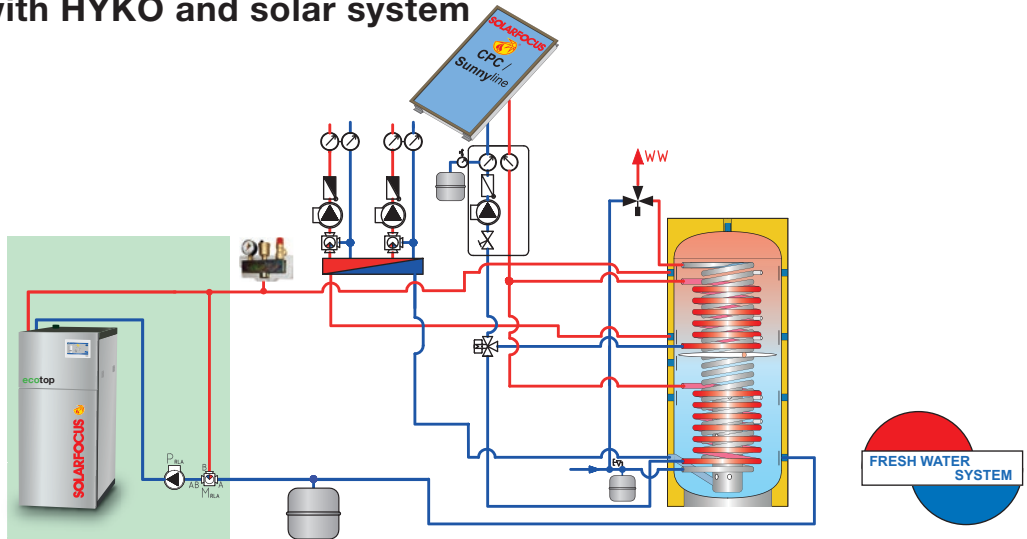

ecotop with stratified storage tank, solar system and DHW tank

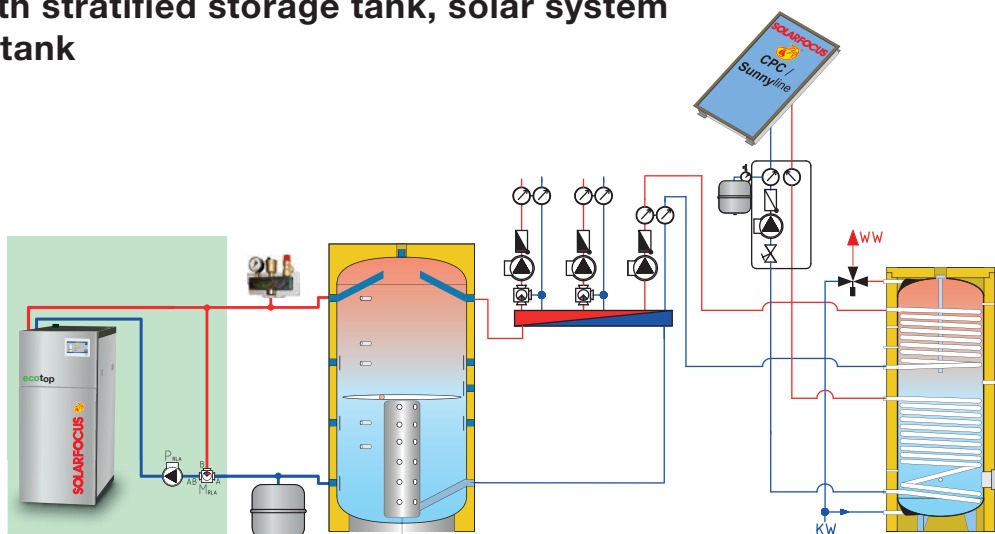

Buffer storage tank

- + We highly recommend the use of a buffer storage tank
- + Perfect adaption to the required heat load

- + Minimizes the boiler starts and maximizes the life of your boiler
- + Can be perfectly combined with solar systems

Flue gas connection on the top

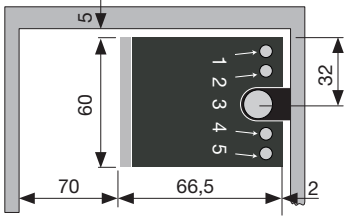

Flue gas connection at the back

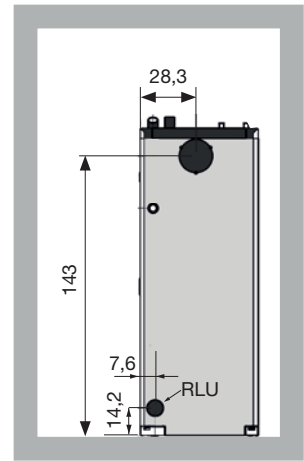
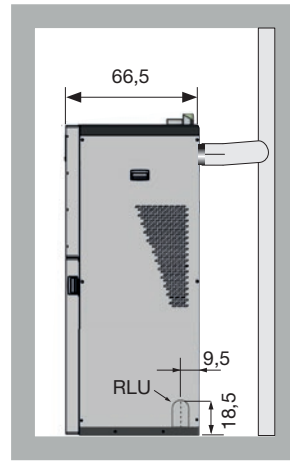
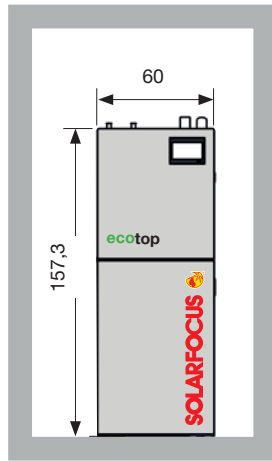
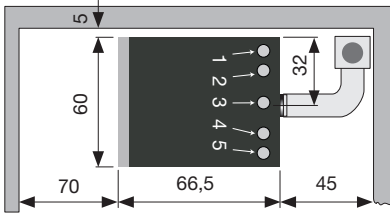

1) return, 2) flow, 3) flue gas connection, 4) return air pellet hose, 5) pellet hose

ecotop^{zero} and ecotop^{light}

		15	20	24
Power range	[kW]	4,6 - 15,4	5,9 - 19,7	7,2 - 24
Energy efficiency class of the product		A+ ➔	A+ ➔	A+ ➔
Energy efficiency class of the system (with control system)		A++ ➔	A++ ➔	A++ ➔
Height incl. adjustable feet (without connections)* H	[cm]	157	157	157
Flue pipe diameter	[mm]	100 / 130	100 / 130	100 / 130
Height of flue pipe center* D	[cm]	143	143	143
Weight	[kg]	280	280	280
Water content	[l]	55	55	55
Integrated pellet storage container	[l]	55	55	55
Ash box volume	[l]	20,3	20,3	20,3
Necessary room height	[cm]	185	185	185
Thermal overload protection			not necessary	

* Adjustable feet at maximum depth of thread

Quality made in Austria

- ✓ Biomass heating
- ✓ Solar installation
- ✓ Heat Pumps
- ✓ Fresh water technology



Products for



Pellets



Pellets + Log wood



Log wood



Wood chips



Solar energy



Fresh water



Heat pump

Your personal advisor

Austria

SOLARFOCUS GmbH, Werkstrasse 1, A-4451 St. Ulrich/Steier

office@solarfocus.at
www.solarfocus.at

Tel.: 07252 50 002 - 0
Fax: 07252 50 002 - 10